

SPRO®

VI-MTR04-B

IP Home Intercom Monitor.



Key Features:

- Android 8.1
- User-Friendly UI
- Ethernet and Wi-Fi
- 7" TFT Capacitive touch Screen, 1024×600
- Quick configuration for villa system

SPECIFICATIONS

Model Number	VI-MTR04-B
Main Processor	Embedded processor
Operating System	Android 8.1
Network Protocol	IPv4, TCP, SIP, UDP, RTSP
Basic	
Screen Type	Capacitive Touchscreen
Display	7 inch TFT LCD
Screen Resolution	1024x600
Video Compression	H.264
Audio Compression	PCM
Audio Input	1 omnidirectional microphone
Audio Output	Built-in 1W speaker
Audio Mode	Two-way Audio
Audio Enhancement	Echo suppression / DNR
Audio Bit Rate	16KHz, 16 Bit

(continued)

Function	
Communication Mode	Full digital
Information Release	Text announcements released by the management center can be viewed.
Elevator Control	You can control the elevator through the indoor monitor
Leave Videos or Text Messages	Yes (SD card is needed(Max. 256GB))
DND Mode	Do not disturb period can be set;
Number of Extensions	Villa: 4 Apartment: 9
Wi-Fi	Yes
Wireless Standard	IEEE802.11b/802.11g/802.11n
Wireless Frequency Range	2.4 GHz
Wireless Security Encryption	64/128bit WEP, WPA/WPA2, WPA-PSK/WPA2-PSK, WPS
Performance	
Casing	PC + ABS
Port	
RS-485	1
Alarm Input	8
Alarm Output	1
Power Output	1 12V/100mA
Door Bell	Yes (use any alarm input port)
Network	1 10M/100M Ethernet
Alarm	
SOS	Yes
General	
Appearance Colour	Black
Power Supply	12V DC 1A POE(802.3AF)
Installation	Surface Mount
Certifications	CE; FCC
Accessory	Surface mount bracket, alarm ribbon cable, RS-485 cable, and power-supply pins are provided
Dimensions	189.6 mm × 134.6 mm × 26.0 mm (7.50" × 5.30" × 1.00")

(continued)

Operating Temperature	-10 °C to +55 °C (+14 °F to 131 °F)
Operating Humidity	10%–95% RH (non-condensing)
Operating Altitude	Beneath 3,000 m (9,842.52 ft)
Power Consumption	≤1.5W (standby), ≤7W (working)
Net Weight	385 g (0.85 lb)
Gross Weight	490 g (1.08 lb)

Dimensions (mm[inch])

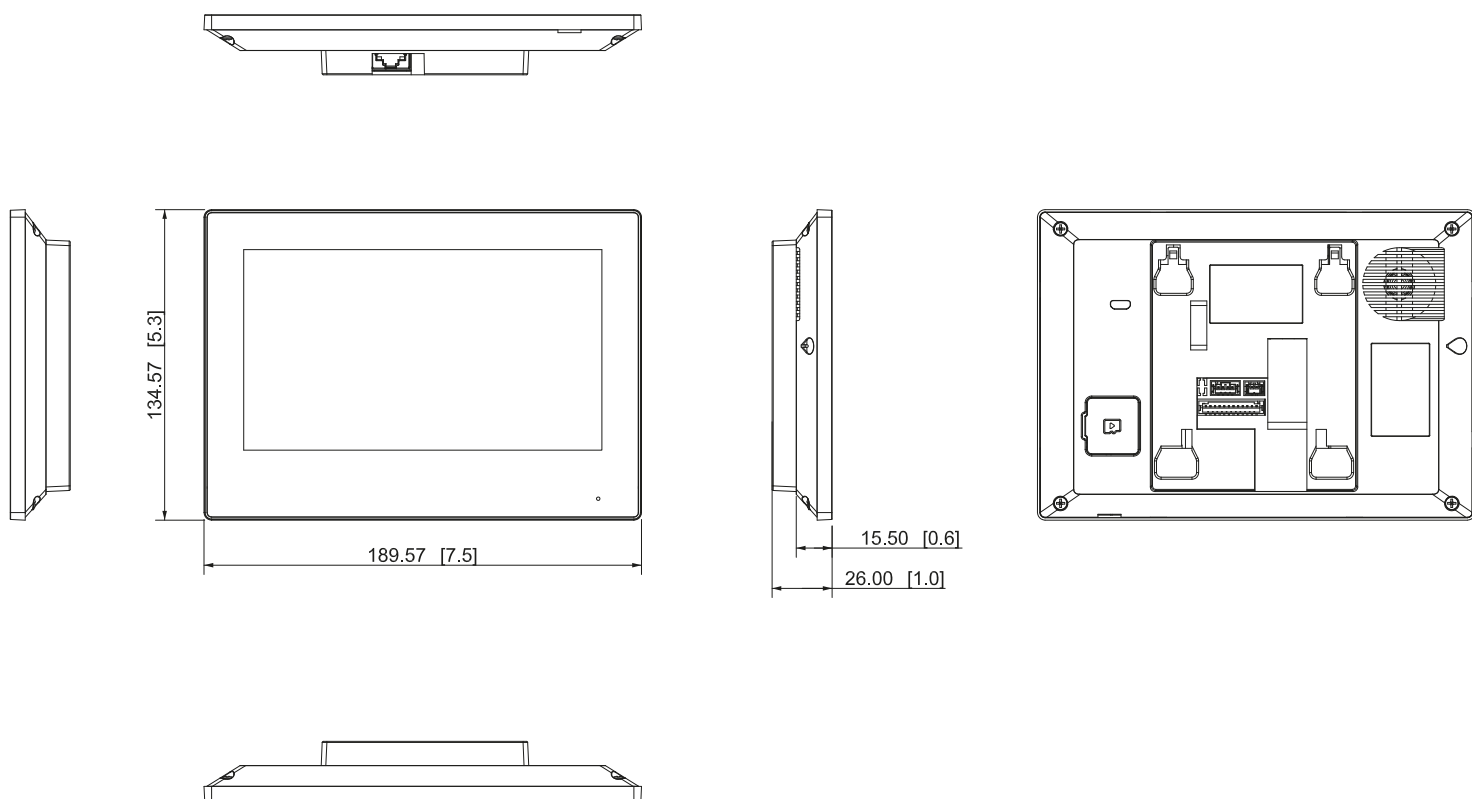

All specifications are subject to change without notice. Copyright © Luxrite Ltd. All rights reserved